

HIGH SPEED HDMI™ CABLE WITH ETHERNET,8K SUPPORT

NOTE:

- Electrical properties:
 - Tested by TOATLPHASE Advanced Cable Tester 2 for HDMI2.1 48G
Support 7680*4320 30Hz 4:4:4
Support 7680*4320 60Hz DSC
 - Tested by Nivida GTX3080 ,TV 4096*2160 120HZ
4:4:4 or RGB 4:4:4 12bit pass
- ROHS 2.0 and REACH
- California Proposition 65 compliant

MODEL LIST

Model	Length	DSP
	1000mm	4K*2K 120HZ 4:4:4 12bit
	1500mm	4K*2K 120HZ 4:4:4 12bit
8K HDMI2.1 cable 2M	2000mm	4K*2K 120HZ 4:4:4 12bit
8K HDMI2.1 cable 3M	3000mm	4K*2K 120HZ 4:4:4 12bit

MATERIAL LIST

⑤	DUST COVER	PE, COLOR: TRANSPARENT	2					
④	CABLE	(1/0.254BC*1P+1/0.254BC+AM)*5C+1/0.254BC*4C+AM+1/0.254BC+128/0.12ALMG+PVC OD:6.0±0.2MM COLOR: BLACK	L	Hunter AV Technologies				
				DRAW No.		NAME	HDMI2.1 CABLE	
③	OUTER MOLD	BLACK PVC	2	9276, 9277		MAPE	TOLERANCE	
②	SHELL	ABS+METALLIZED,COLOR:SILVERY	2	MODEL No.	8K HDMI2.1 cable 2M~3M		X. ±1.00 X.X ±0.50	
①	CONNECTOR	HDMI2.1MALE ,RUBBER CORE:RED,GOLD PLATED PIN,GOLD PLATED SHELL	2	APPROVE BY	CHECK BY	DRAW BY	SCALE	MM
No.	PART NAME	DESCRIPTION	QTY	CSSO	S. Daniel		PAGE	1/1

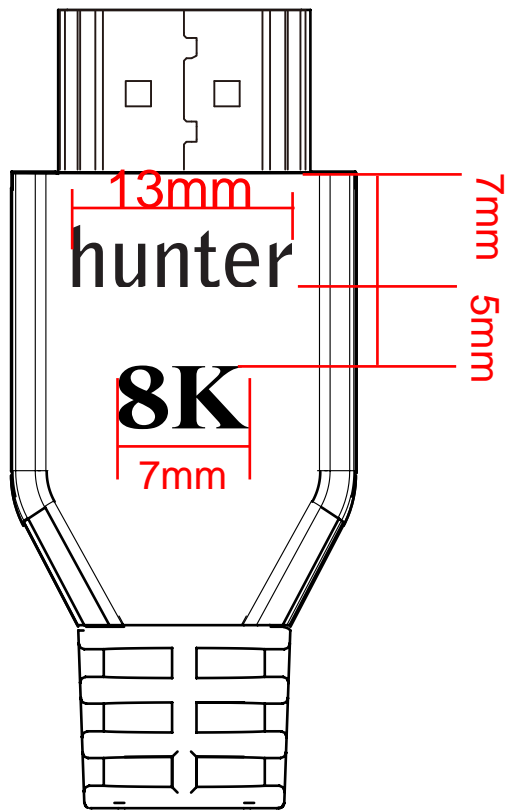

hunter

8K